



# STAYER

## LT1401EK

**ES** Manual de instrucciones

**IT** Istruzioni d'uso

**GB** Operating instructions

**FR** Instructions d'emploi

**P** Manual de instruções

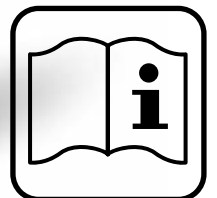
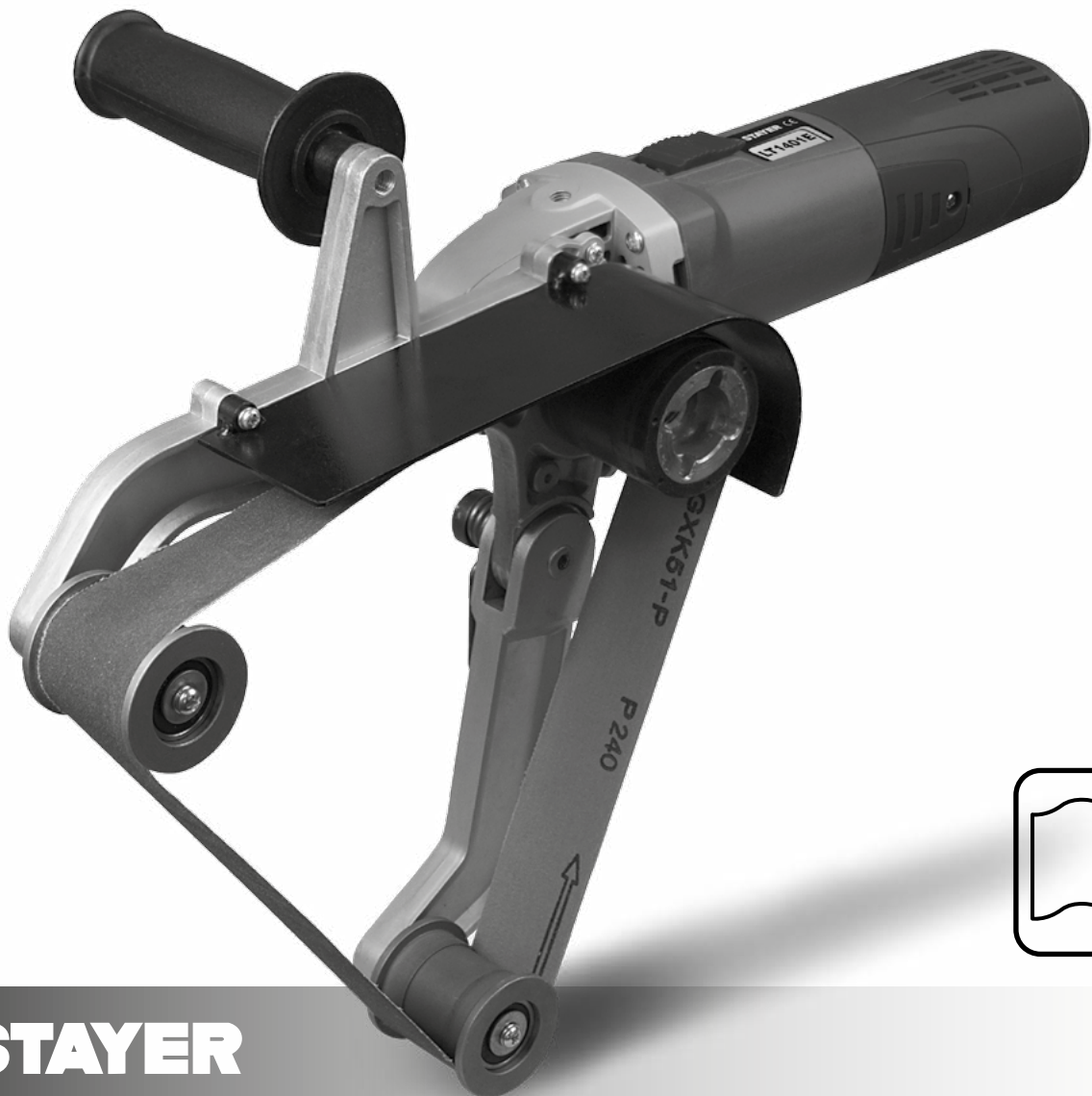

## STAYER

Área Empresarial Andalucía - Sector 1  
C/ Sierra de Cazorra, 7  
28320 - Pinto (Madrid) SPAIN  
Email: sales@grupostayer.com  
Email: info@grupostayer.com

[www.grupostayer.com](http://www.grupostayer.com)

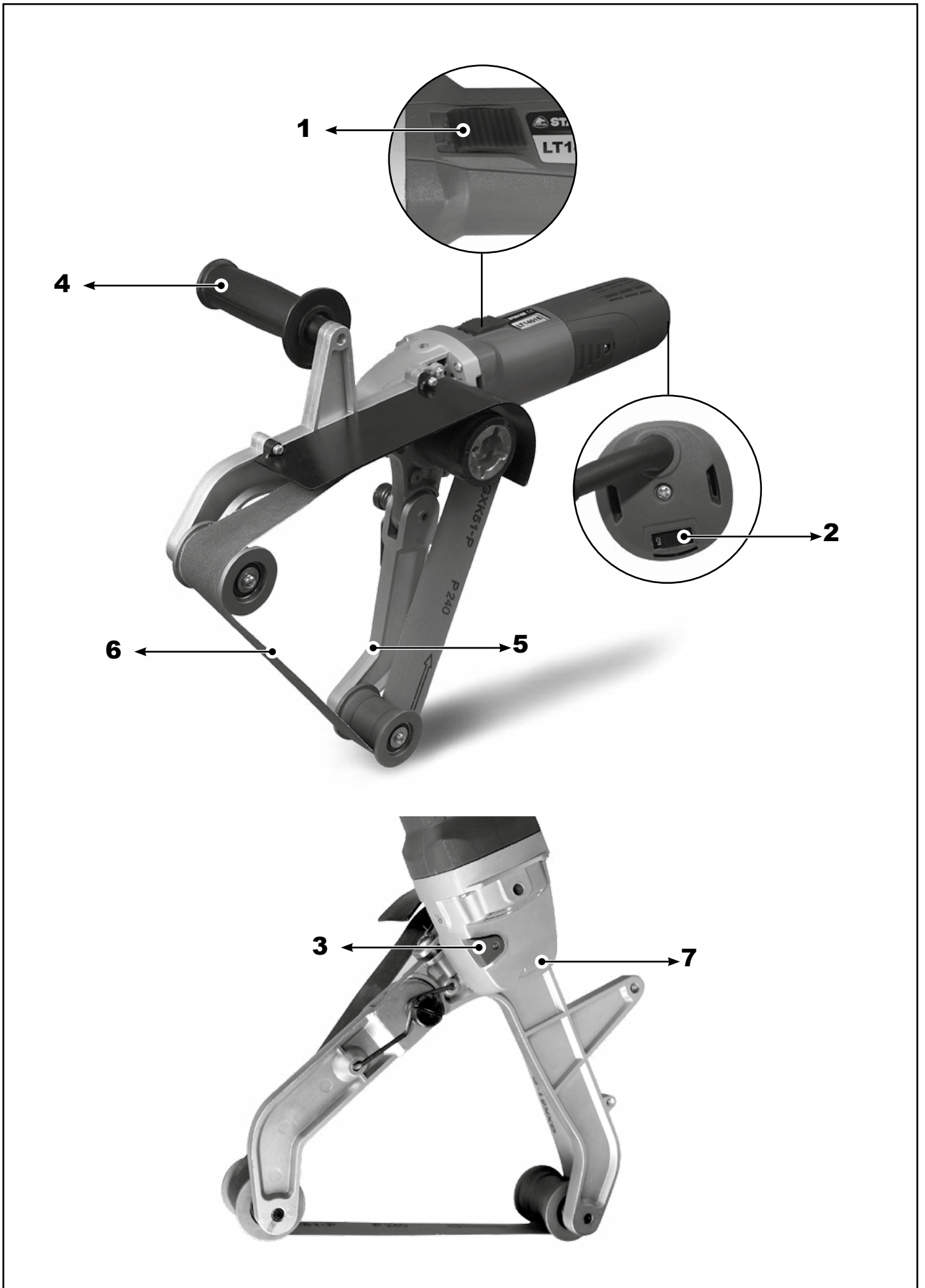



		<b>LT1401EK</b>	
		W	1400
		min <sup>-1</sup>	750-3000
		mm	40x760
		mm	180
		M/S	2.7-8.5
		Kg	3.7
	K=3db	L <sub>PA</sub> dB(A)	68
		L <sub>WA</sub> dB(A)	99
	K=3 m/s <sup>2</sup>	a <sub>h</sub> m/s <sup>2</sup>	4

This manual is consistent with the date of manufacture of your machine, you will find information on the technical data of the machine acquired manual check for updates of our machines on the website: [www.grupostayer.com](http://www.grupostayer.com)

**OPERATING INSTRUCTIONS**

Dear Customer, Thank you for the trust you have placed in us by buying a STAYER power tool. Each STAYER power tool is carefully tested and subject to strict quality controls by STAYER's quality assurance.

Nevertheless, the service life of a power tool depends to a great extent on you. Please observe the information contained in these instructions and the enclosed documentation. The more carefully you treat your STAYER power tool, the longer it will provide dependable service.

**CONTENTS**

1 Specified Use..... 12  
 2 General Safety Instructions ..... 12  
 3 Illustrated description ..... 13  
 4 Commissioning ..... 13  
 5 Use ..... 13  
 6 Cleaning and Maintenance ..... 13  
 7 Accessories ..... 13  
 8 Maintenance and service instructions..... 13  
 9 Regulations ..... 14

**1 Specified Use**

The wraparound tube sander is for glazing, tarnishing, texturing, polishing and smoothing pipes without the use of water.

The user bears sole responsibility for any damage caused by improper use.

Generally accepted accident prevention regulations and the enclosed safety information must be observed.

**2 Special Safety Instructions**

**Hold power tool by insulated gripping surfaces, because the belt may contact its own cord.**

Cutting a "live" wire may make exposed metal parts of the tool "live" and could give the operator an electric shock.

Flying sparks are created when sanding metal. Ensure that no persons are in danger. Due to the risk of fire, all combustible materials must be removed from the work area (area affected by flying sparks).

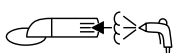

During machining, of metals in particular, conductive dust can form deposits inside the machine. This can lead to the transfer of electrical energy onto the machine housing. This can mean a temporary danger of electric shocks. This is why it is necessary when the machine is running to blow compressed air through the rear ventilation slots of the machine regularly, frequently and thoroughly. Here, the machine must be held firmly.

We recommend using a stationary extractor system and connecting a residual current circuitbreaker (FI) upstream. When the machine is shut down via the FI circuit-breaker, it must be checked and cleaned. See chapter 8 Cleaning for more information on cleaning the motor.

Dust from material such as paint containing lead, some wood species, minerals and metal may be harmful. Contact with or inhalation of the dust may cause allergic reactions and/or respiratory diseases to the operator or bystanders.

Certain kinds of dust are classified as carcinogenic such as oak and beech dust especially in conjunction with additives for wood conditioning (chromate, wood preservative). Material containing asbestos must only be treated by specialists.

- Where the use of a dust extraction device is possible it shall be used.
- The work place must be well ventilated.
- The use of a dust mask of filter class P2 is recommended.

Follow national requirements for the materials you want to work with.

Materials that generate dusts or vapours that may be harmful to health must not be processed.

Wear ear protectors. Exposure to noise can cause hearing loss.

Wear protective gloves.



**Always wear protective goggles.**

Secure the workpiece against slipping, e.g. with the help of clamping devices.

Always guide the machine with both hands on the handles provided. Loss of control can cause personal injury.

Never place your hand near rotating parts of the device or near the rotating sanding belt.

Remove sanding dust and similar material only when the machine is not in operation.

Pull the plug out of the plug socket before any adjustments, conversions or servicing are performed.

The rated speed of the sanding belt must be at least equal to the belt speed in idling marked on the power tool. A sanding belt running faster than its rated speed can break and fly apart.

Check prior to each use that the sanding belt is correctly attached and is completely on the rollers.

Carry out a trial run: Allow the machine to run at idling speed for 30 seconds in a safe location. Stop immediately if significant vibrations occur or if other defects are noted. If such a situation occurs, check the machine to determine the cause.

### 3 Illustrated description

- 1 Switch ON / OFF.
- 2 Adjusting wheel for setting belt speed.
- 3 Spindle lock.
- 4 Additional handle.
- 5 Tensioner arm for replacing the sanding belt.
- 6 Sanding belt.
- 7 Arrow (direction of rotation of drive shaft).

### 4 Commissioning



**Before plugging in, check that the rated mains voltage and mains frequency, as stated on the rating label, match with your power supply.**

**Attaching the additional handle.**



**Always work with the additional handle attached (4)! Secure the additional handle by screwing it tightly to the left or right.**

### 5 Use

#### 5.1 On/Off switch, continuous activation



**Always guide the machine with both hands.**



**The machine must not be allowed to draw in additional dust and shavings. When switching the machine on and off, keep it away from dust deposits.**



**After switching off the machine, only place it down when the motor has come to a standstill.**



**In continuous operation, the machine continues running if it is forced out of your hands. Therefore, always hold the machine using the handles provided, stand in a safe position and concentrate.**

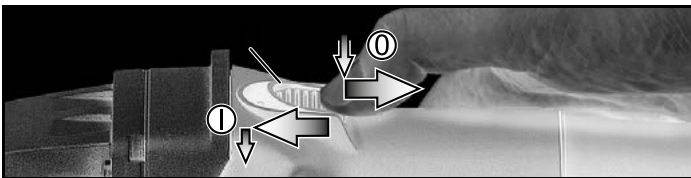

**Switching on/Continuous activation:** Push sliding switch (1) forward. For continuous activation, now tilt downwards until it engages.

**Switching off:** Press the rear end of the slide switch (1) and release.

#### 5.2 Setting belt speed

The belt speed can be preset via the setting wheel (2) and is infinitely variable.

Positions 1-6 correspond approximately to the following belt speeds:

1 .....	2.7 m/s	4 .....	6.3 m/s
2 .....	3.8 m/s	5 .....	7.6 m/s
3 .....	5.1 m/s	6 .....	8.5 m/s

#### 5.3 Sanding belt replacement

- Release the tensioner arm (5) and remove the sanding belt (6).
- Place the new sanding belt on the rollers such that its direction of circulation (arrows on the inside of the sanding belt) matches the arrow (7) on the gearbox.
- Release the tensioner arm (5).
- Ensure that the sanding belt is completely on the rollers.

#### 5.4 Sanding procedure

Place the machine on the material such that the sanding belt is parallel to the surface of the workpiece.

When working, please ensure that the machine is operated at right angles to the pipe so that the belt does not fall off the rollers.

Using the additional handle, the belt can be pressed against the pipe and at same time placed around it. The angle of contact and the cutting output may be changed by the contact pressure.

Keep the machine in constant motion because otherwise recesses could be produced in the material.

### 6 Cleaning and Maintenance

**Motor cleaning:** blow compressed air through the rear ventilation slots of the machine regularly, frequently and thoroughly. Here, the machine must be held firmly.

### 7 Accessories

Use only genuine STAYER accessories.

If you need any accessories, check with your dealer.

The dealer needs to know the exact model of your power tool in order to select the correct accessory.

For a complete range of accessories, see [www.grupostayer.com](http://www.grupostayer.com) or the main catalogue.

### 8. Maintenance and service instructions

#### 8.1 Repair service

Our after-sales service responds to your questions concerning maintenance and repair of your product as well as spare parts.

Exploded views and information on spare parts can also be found under: [info@grupostayer.com](mailto:info@grupostayer.com)

Our customer consultants answer your questions concerning best buy, application and adjustment of products and accessories.

## 8.2 Warranty

### Warranty card

Included in the documentation that accompanies this equipment, you should find the warranty card. You should fill out the card completely and return to vendor with a copy of purchasing receipt or invoice and you should receive a receipt.

**Note: If you cannot find the warranty card within the documentation, you must ask for it through your supplier.**

The warranty is limited only to manufacturing defects and expire if pieces have been removed or manipulated or repaired other than the manufacturer.

## 8.3 Disposal and recycling

The machine, accessories and packaging should be sorted for environmental-friendly recycling. Only for EC countries:

### Do not dispose of power tools into household waste!



According to the European Guideline 2002/96/EC for Waste Electrical and Electronic Equipment and its implementation into national right, power tools that are no longer usable must be collected separately and disposed of in an environmentally correct manner.

**Subject to change without notice.**

## 9. Regulations

### 9.1 Technical Data



= Rated power input.



= Load speed.



= Dimensions sanding band.



= Maximum diameter of the tube.



= Speed of the tape.



= Weight.



$L_{WA}$  = Sound power level.



$L_{PA}$  = Sound pressure level.



= Vibration.

The values given are valid for nominal voltages [U] 230/240 V-50/60 Hz - 110/120 V - 60Hz. For lower voltage and models for specific countries, these values can vary. Please observe the article number on the type plate of your machine. The trade names of the individual machines may vary.

### Noise/Vibration Information

Noise determined according to EN 60745.

The typical sound pressure level of appliance determined with a filter A product are: Sound pressure level 68 dB(A); sound power level 99 dB(A). Tolerance K=3 dB.



### Wear hearing protection!

Total vibration values (vector sum of three directions) determined according to EN 60745: Sanding drywall  $a^h=4 \text{ m/s}^2$ ,  $K=3 \text{ m/s}^2$ .

The vibration emission level given in this information sheet has been measured in accordance with a standardised test given in EN 60745 and may be used to compare one tool with another. It may be used for a preliminary assessment of exposure.

The declared vibration emission level represents the main applications of the tool. However if the tool is used for different applications, with different accessories or poorly maintained, the vibration emission may differ. This may significantly increase the exposure level over the total working period.

An estimation of the level of exposure to vibration should also take into account the times when the tool is switched off or when it is running but not actually doing the job. This may significantly reduce the exposure level over the total working period.

Identify additional safety measures to protect the operator from the effects of vibration such as: maintain the tool and the accessories, keep the hands warm, organisation of work patterns.

### 9.2 EU declaration of conformity

The undersigned: STAYER IBERICA, S.A.

With address at:

Calle Sierra de Cazorla, 7  
 Área Empresarial Andalucía - Sector 1  
 28320 PINTO (MADRID)  
 Tel.: +34 91 691 86 30 / Fax: +34 91 691 86 31

CERTIFIES

That the machine:

Type: **PIPE SANDER**

Models: **LT1401EK**

I declare under our responsibility that the product described under "Technical Data" is in accordance with the following standards or standardized documents: UNE-EN 60745-1:2010/A11:2011, UNE-EN 60745-2-4:2010/A11:2012 according to regulations 2006/42/CE, 2004/108/CE, 2011/65/UE.

*January, 2017*



CE  RoHS

**Ramiro de la fuente**  
Managing Director



**STAYER**

Área Empresarial Andalucía - Sector 1  
C/ Sierra de Cazorla, 7  
28320 - Pinto (Madrid) SPAIN  
Email: [sales@grupostayer.com](mailto:sales@grupostayer.com)  
Email: [info@grupostayer.com](mailto:info@grupostayer.com)



[www.grupostayer.com](http://www.grupostayer.com)